

PLAN OF PROPOSED CONCRETE ATTENUATION TANK

SCALE 1:50

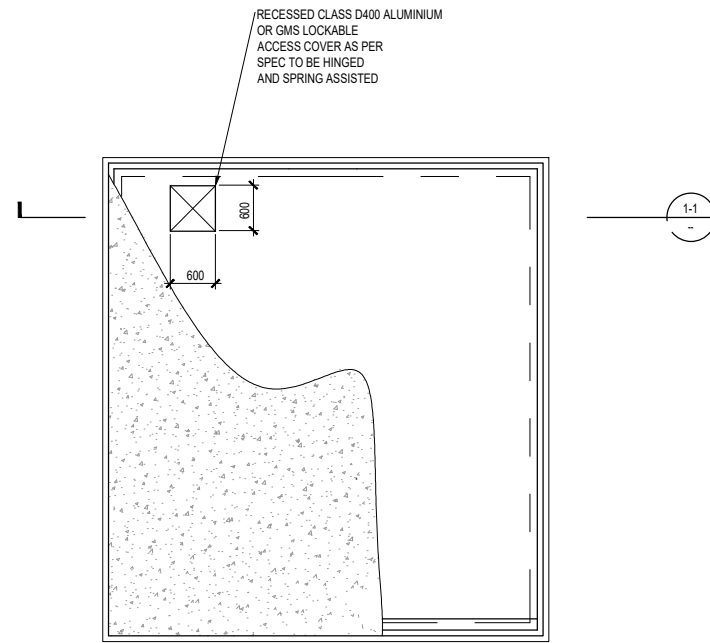

PLAN OF PROPOSED CONCRETE ATTENUATION TANK ROOF

SCALE 1:50

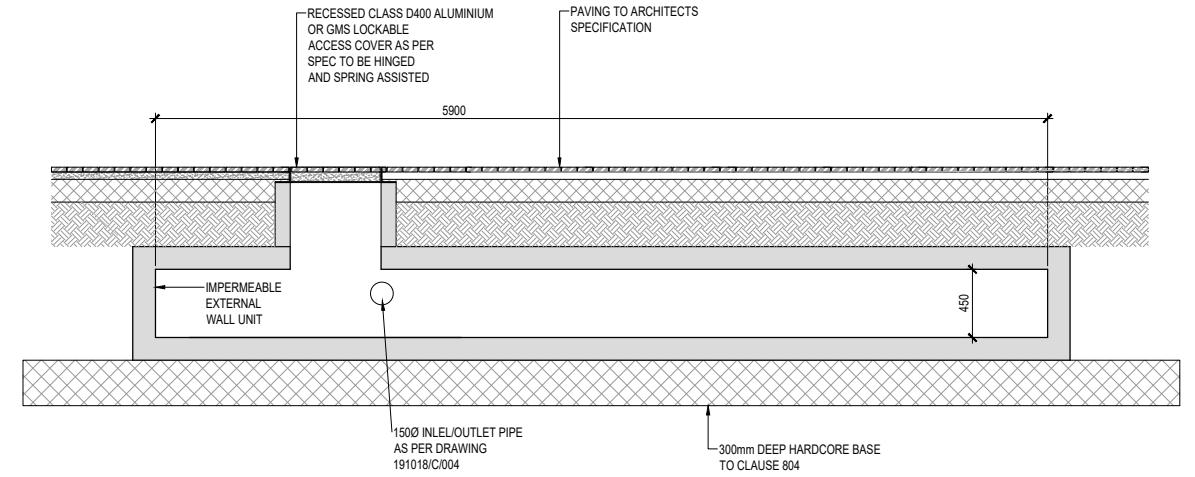

PROPOSED SECTION 1-1

SCALE 1:25

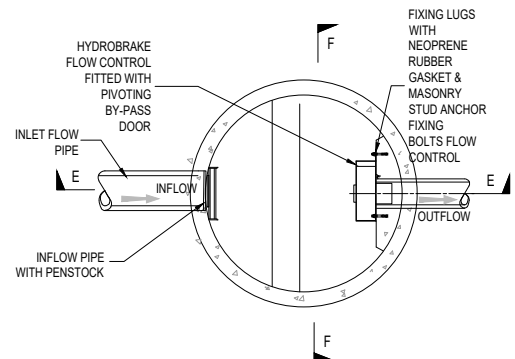

TYPICAL HYDROBRAKE MANHOLE DETAIL -

PLAN

SCALE 1:200

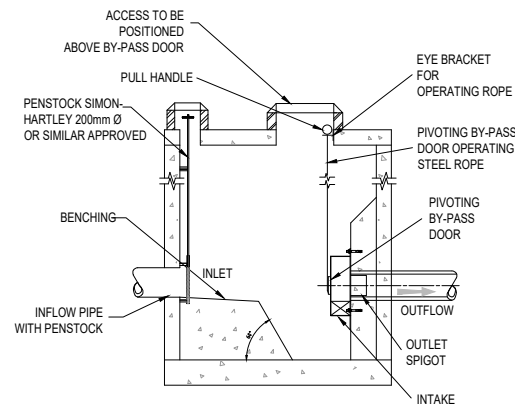

TYPICAL HYDROBRAKE MANHOLE

DETAIL SECTION E-E

SCALE 1:200

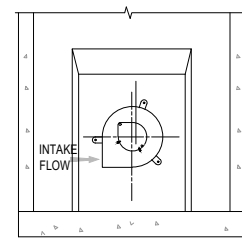

TYPICAL HYDROBRAKE MANHOLE

DETAIL SECTION F-F

SCALE 1:200

Issue Register				
No.	Date	Revision	Drawn	Checked/Approved
PL1	26/06/20	PLANNING ISSUE	MT	MJP

GENERAL NOTES:-

- THIS DRAWING TO BE READ IN CONJUNCTION WITH ALL RELEVANT ARCHITECTS & ENGINEERS DRAWINGS & SPECIFICATIONS.
- DO NOT SCALE. USE FIGURED DIMENSIONS ONLY.
- THE CONTRACTOR SHALL VERIFY ALL DIMENSIONS & ELEVATIONS WITH ARCHITECTURAL DRAWINGS PRIOR TO START OF CONSTRUCTION. ALL DISCREPANCIES TO BE NOTIFIED, IN WRITING TO ENGINEERS & ARCHITECTS FOR RESOLUTION.
- ALL DIMENSIONS ON DRAWINGS ARE IN MILLIMETRES UNLESS OTHERWISE NOTED.

ALL SETTING OUT DIMENSIONS TO BE CHECKED AGAINST ARCHITECTS DRAWINGS. ARCHITECTS DRAWINGS TO TAKE PRECEDENCE.

ABBREVIATIONS:-

- | | |
|------|------------------------|
| BTM | BOTTOM |
| C/C | CENTRE TO CENTRE |
| CTRS | CENTRES |
| SFL | STRUCTURAL FLOOR LEVEL |
| FFL | FINISHED FLOOR LEVEL |
| TOC | TOP OF CONCRETE |
| TP | TOP |
| TOS | TOP OF STEEL |
| UNO | UNLESS NOTED OTHERWISE |



comhairle chontae na mí
meath county council

PLANNING

Client: MEATH COUNTY COUNCIL	
Project: BETTYSTOWN LIBRARY SEAVIEW TERRACE, BETTYSTOWN	
Drawing Title: PROPOSED ATTENUATION TANK DETAILS	
Project No: 191018	Scale: 1:200@A3
Drawing No: 191018/C/035	Rev: PL1
Drawn: MT	Checked: MJP
	Date: 01/05/20



Martin Peters Associates
Consulting Engineers

Ormeau Road
Kilenny

T + 353 91 7702761
F + 353 91 7702728
E info@mpa.ie